

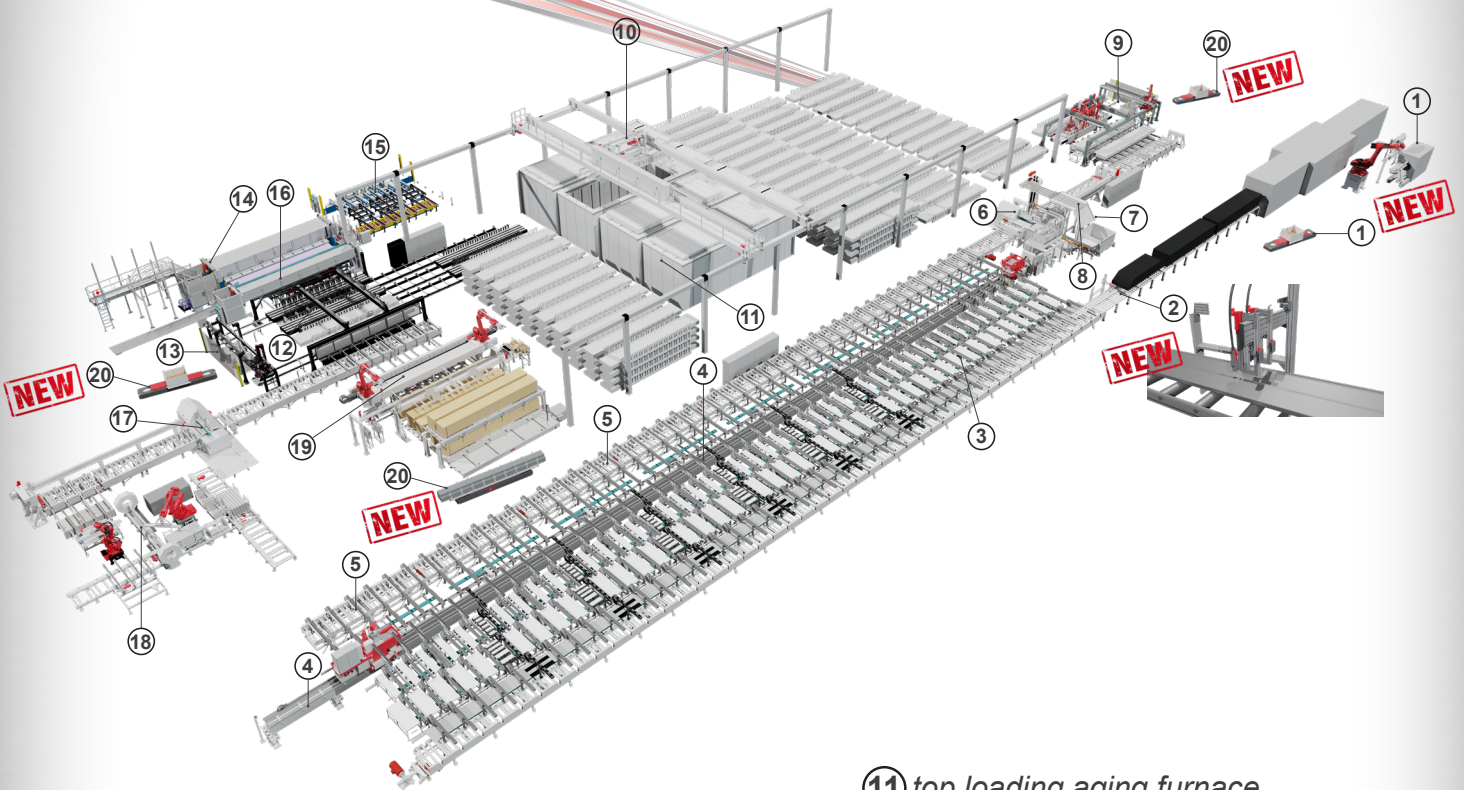

World leader in

**AUTOMATIC**  
extrusion plants



- ① *billet loader & die transport*
- ② *inline profile marking / automatic scrap marking*
- ③ *cooling table*
- ④ *no-man stretcher*
- ⑤ *saw infeed conveyor*
- ⑥ *final saw - inline cut to length*
- ⑦ *short scrap handling*
- ⑧ *automatic sample handling*
- ⑨ *stacker*
- ⑩ *automatic crane*
- ⑪ *top loading aging furnace*
- ⑫ *destacker*
- ⑬ *spacer handling*
- ⑭ *cardboard dispenser*
- ⑮ *bundeling station*
- ⑯ *paper dispenser*
- ⑰ *precision saw*
- ⑱ *automatic packing for short profiles  
automatic quality check*
- ⑲ *APL - automated packing line  
semi-automated packing*
- ⑳ *AGV - automated guided vehicle*

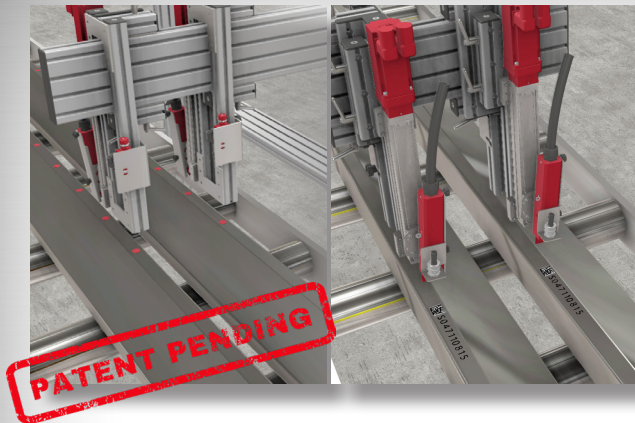

## INLINE PROFILE MARKING ISO 9001 CONFORM

- ▶ unique profile identification by text and/or QR code
- ▶ inline profile marking directly after press
- ▶ marking of reject profiles  
(up to 560°C surface temperature)
- ▶ 100% traceability back to the billet
- ▶ process-integrated marking and printing solution

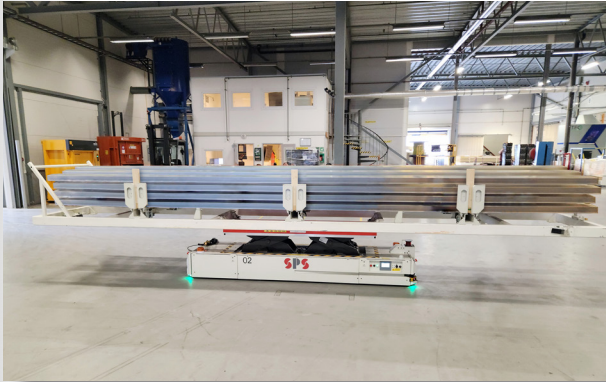

## AGV - AUTOMATIC GUIDED VEHICLES

for fully automatic  
transport of:

- ▶ dies
- ▶ skips
- ▶ single layers
- ▶ scrap baskets
- ▶ spacer boxes
- ▶ ready customer packages



## APL - AUTOMATED PACKING LINE

- ▶ flexible semi- and fully automated packaging system  
designed for paper, plastic or carton interlayers
- ▶ automatic scrap detection
- ▶ loading and unloading of bundles with AGV

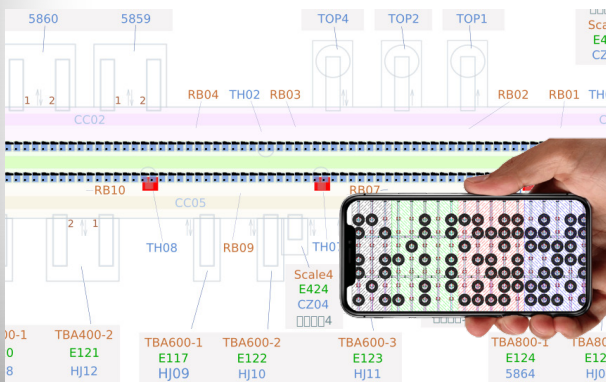

## PROCESS MANAGEMENT SYSTEM

- ▶ warehouse management system
- ▶ transport control system
- ▶ open interfaces (TCP/IP, OPC-UA, ...)
- ▶ live visualization
- ▶ simulation
- ▶ project-specific programming

0048\_2406\_V001\_E

sps.at

**SPS Technik GmbH**  
Gewerkepark 7  
4300 St. Valentin / Austria  
Tel. +43 (0)7435 / 54048-0

**SPS Maschinenbau GmbH**  
Am Nussbaumhof 29  
4813 Altmünster / Austria  
Tel. +43 (0)7612 / 87432-0







## CRANE

- ▶ *design of entire intralogistic concepts for in-house transport and warehouse logistics*

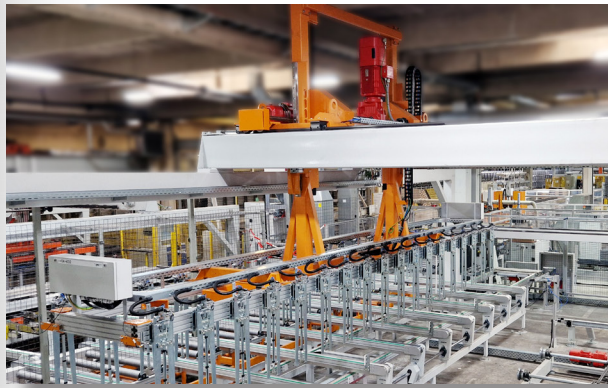

## STACKER - DESTACKER

- ▶ *floor conveyor systems*
- ▶ *automatic cranes*
- ▶ *AGVs*
- ▶ *stacker - destacker*



## SAW

- ▶ *high precision final saws*
- ▶ *inline cut to length*
- ▶ *automatic sample handling*
- ▶ *automatic scrap handling*



## COOLING TABLE

- ▶ *tooth belt conveyors for precise transport*
- ▶ *safety oriented and maintenance friendly design*
- ▶ *controlled cooling system*

0048\_2406\_V001\_E

**sps.at**

**SPS Technik GmbH**  
Gewerbepark 7  
4300 St. Valentin / Austria  
Tel. +43 (0)7435 / 54048-0

**SPS Maschinenbau GmbH**  
Am Nussbaumhof 29  
4813 Altmünster / Austria  
Tel. +43 (0)7612 / 87432-0







## STRETCHER

- ▶ up to 200t force, especially for automotive profiles
- ▶ high precision servo hydraulic control system
- ▶ high certificated safety standard



## PACKAGING PLANT

- ▶ ergonomic packing stations
- ▶ automatic packing material infeed

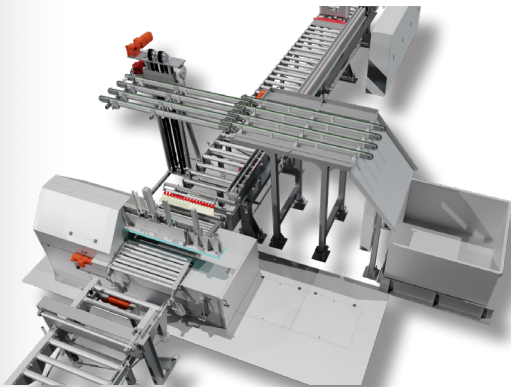

## AUTOMATIC SCRAP HANDLING

- ▶ inline short scrap handling
- ▶ inline long scrap handling
- ▶ transport to scrap container

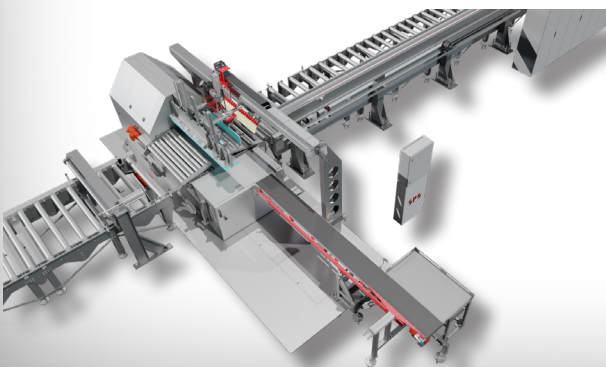

## AUTOMATIC SAMPLE HANDLING

- ▶ inline automatic sample handling
- ▶ transport out of safety area

0048\_2406\_V001\_E

**sps.at**

**SPS Technik GmbH**  
Gewerbepark 7  
4300 St. Valentin / Austria  
Tel. +43 (0)7435 / 54048-0

**SPS Maschinenbau GmbH**  
Am Nussbaumhof 29  
4813 Altmünster / Austria  
Tel. +43 (0)7612 / 87432-0

